



PRESCOTT PRESERVATION COMMISSION A G E N D A

**PRESCOTT PRESERVATION COMMISSION
REGULAR MEETING/PUBLIC HEARING
FRIDAY, February 12, 2021
8:00 AM**

**Virtual Zoom Meeting
201 S. CORTEZ STREET
PRESCOTT, ARIZONA
(928) 777-1100**

The following agenda will be considered by the **Prescott Preservation Commission at its public hearing to be held at 8:00 AM on February 12, 2021 via Zoom Virtual Meeting.** Notice of this meeting is given pursuant to *Arizona Revised Statutes*, Section 38-431.02.

The Community Development Department of Prescott AZ is inviting you to a scheduled Zoom meeting.

Topic: Historic Preservation Commission
Time: Feb 12, 2021 08:00 AM Arizona

Join Zoom Meeting

<https://us02web.zoom.us/j/87816486192>

Dial by your location

1 669 900 6833 or
1 346 248 7799

Meeting ID: 878 1648 6192

- I. CALL TO ORDER – Housekeeping – Please keep your phone or PC microphone on mute unless you are speaking to minimize background noise.**

Please identify yourself each time you speak so that we can record your comments in the minutes and properly count motions and votes.

II. ATTENDANCE

Members

Robert Burford, Chairman
Michael Mirco, Vice-Chairman
Richard Sprain
Mary Ann Suttles

Mike King
James McCarver
Rob Johnson

III. REGULAR AGENDA

- 1. Approval of the minutes from the January 8, 2021 meeting.**

2. **HP21-001** 132&134 S Montezuma St. APN: 109-02-013. Historic Preservation District #1, Courthouse Plaza. Request approval for three new storefront awnings for Arts Prescott Gallery.

IV. UPDATE OF CURRENT EVENTS

V. ADJOURNMENT

CERTIFICATION OF POSTING OF NOTICE

The undersigned hereby certifies that a copy of the foregoing notice was duly posted at Prescott City Hall on 2/5/2021 at 1:30 PM in accordance with the statement filed by the Prescott City Council with the City Clerk.

Sarah M. Siep

Sarah Siep, City Clerk

THE CITY OF PRESCOTT ENDEAVORS TO MAKE ALL PUBLIC MEETINGS ACCESSIBLE TO PERSONS WITH DISABILITIES. With 72 hours advanced notice, special assistance can be provided for sight and/or hearing-impaired persons at this meeting. Reasonable accommodations will be made upon request for persons with disabilities or non-English speaking residents. Please call the City Clerk (928) 777-1272 to request an accommodation to participate in this public meeting. Prescott TDD number is (928) 445-6811. Additionally, free public relay service is available from Arizona Relay Service at 1-800-367-8939 and more information at www.azrelay.org

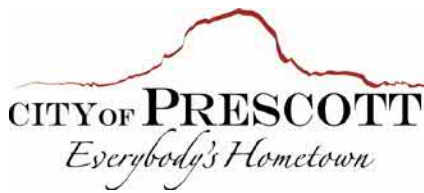

PRESCOTT PRESERVATION COMMISSION MINUTES

**PRESCOTT PRESERVATION COMMISSION
REGULAR MEETING/PUBLIC HEARING
FRIDAY, January 8th, 2021
8:00 AM**

**Virtual Zoom Meeting
201 S. CORTEZ STREET
PRESCOTT, ARIZONA
(928) 777-1207**

I. CALL TO ORDER

II. ATTENDANCE

Members

Robert Burford, Chairman

Mike King

James McCarver, *Absent*

Michael Mirco, Vice-Chairman

Rob Johnson

Richard Sprain

Mary Ann Suttles

Staff:

Cat Moody- Historic Preservation Specialist

Bryn Stotler- Community Development Director

George Worley- Planning Manager

Tammy DeWitt- Community Planner

Council:

Phil Goode, Liaison

III. REGULAR AGENDA

The meeting was called to order at 08:11 am by Chair Burford.

1. Approval of the minutes from the December 11, 2020 meeting.

Commissioner King made a motion to approve the minutes of December 11, 2020. Commissioner Mirco seconded the motion. The motion passed (6-0).

2. HP20-014 328 Cochise St. APN: 108-01-053. Historic Preservation District #10, Pine Crest. Request approval for window and door replacements.

Historic Preservation Specialist Cat Moody presented an aerial photo of the subject property and explained that it is not listed as a contributor to the (historic) district due to a second story addition, siding and out of character windows that were added to the home. The current owner desires to bring the new windows and doors into compatibility with the district. Ms. Moody presented photos of the existing windows and doors as well as renderings provided by the contractor (Prescott Window and Door). The existing windows will be

replaced with single hung or fixed windows with transom elements above. The new windows will also have bronze finished frames. The proposed front door is Craftsman style with a dentil shelf, the rear doors will be simple, half and full light styles.

Applicant and homeowner Anna Lenko expressed her desire to restore the historical nature of the home, starting with this project. She explained that she got inspiration for the designs by walking around the neighborhood looking at other (historical) homes. Commissioner Mirco asked whether the existing shutters would be replaced; Ms. Lenko responded that she planned on re-painting and replacing. Mr. Mirco and Ms. Moody expressed their opinion that the shutters are not in historical character and that it would be favorable to remove them. Chair Burford asked whether the upper level siding would remain; Ms. Lenko confirmed that it would. Mr. Burford also expressed his support of Mr. Mirco's and Ms. Moody's recommendations to remove the shutters.

Commissioner King made a motion to approve HP20-014. Commissioner Suttles seconded the motion. The motion passed (6-0).

IV. UPDATE OF CURRENT EVENTS OR OTHER ITEMS OF NOTE

Ms. Moody presented the 2021 Preservation Commission meeting schedule and asked if there were any scheduling conflicts; there were no objections.

V. ADJOURNMENT

Meeting Adjourned at 8:42 am

Kaylee Nunez, Recorder

Robert Burford, Chair

**PRESCOTT PRESERVATION COMMISSION
COMMUNITY DEVELOPMENT DEPARTMENT
Staff Report
February 12, 2021**

AGENDA ITEM: HP21-001 Request approval for three new storefront awnings for Arts Prescott Gallery.

Planning Manager: George Worley GW 2/5/21

Director: Bryn Stotler BS 2/5/21

Historic Preservation Specialist: Cat Moody CM 2/5/21

Report Date: February 5, 2021

Historic Preservation District: #1 Courthouse Plaza

APN: 109-02-013

Zoning: DTB

Location: 132 & 134 S Montezuma St

Applicant: A Shade Beyond, Wolfgang Dieterich, 474 EZ St, Prescott AZ 86301

Owner: Field Investments, 8098 E Valley Rd Suite 1, Prescott Valley AZ 86314

Existing Conditions

National Register Status: This building is not listed in the National Register of Historic Places due to significant alterations to the front façade in years past.

The front façade is comprised of two doors that flank either side of a central display window. The south door serves as the entrance for Arts Prescott Gallery, and the north door provides access to an apartment on the 2nd floor.

There currently are no awnings on this building.

Request

The applicant proposes to place three steel, fixed-frame, angled awnings on the first-floor front façade.

There will be a 3 foot 8 inch wide awning over each of the two doors, and there will be a 9 foot 8 inch awning over the central display window. All three awnings extend 4 foot from the building, providing protection for pedestrians along the sidewalk.

Awning fabric will be Sunbrella Slate 4684, a solid medium-to-dark grey color.

Signage will be placed on the 9 inch vertical valance portion of the awning. The address will be printed over each door, and “arts prescott cooperative gallery” will be printed on the central window valance.

See attached sketches, rendering and color sample for the design details.

Analysis

Conformance with the Prescott Historic Preservation Master Plan (HPMP): In part, the HPMP chapter for the Courthouse Plaza Historic District states:

- Use historically consistent signage

Agenda Item: HP21-001, 132 & 134 S Montezuma St

- Encourage the use of fabric awnings throughout the district
- Use only integral and natural colors of a neutral tone, compatible with the building and the district

The awnings and signage elements are compatible with the district guidelines and the style of this building.

Site Visit: Recommended

Recommended Action: Approve HP21-001, Request approval for three new storefront awnings for Arts Prescott Gallery.



**A SHADE
BEYOND**

Shop 928 778-9300
Fax 928 708-9086

474 EZ Street
Prescott, AZ 86301

CLIENT:

PHONE:

DOOR AWNINGS

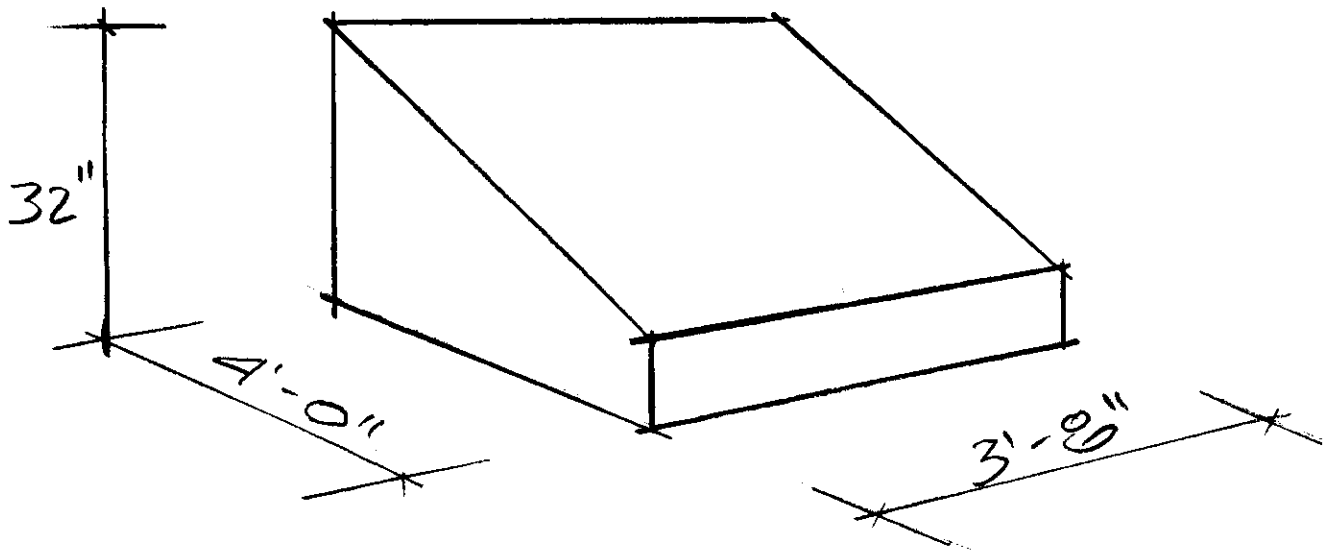

WINDOW AWNING

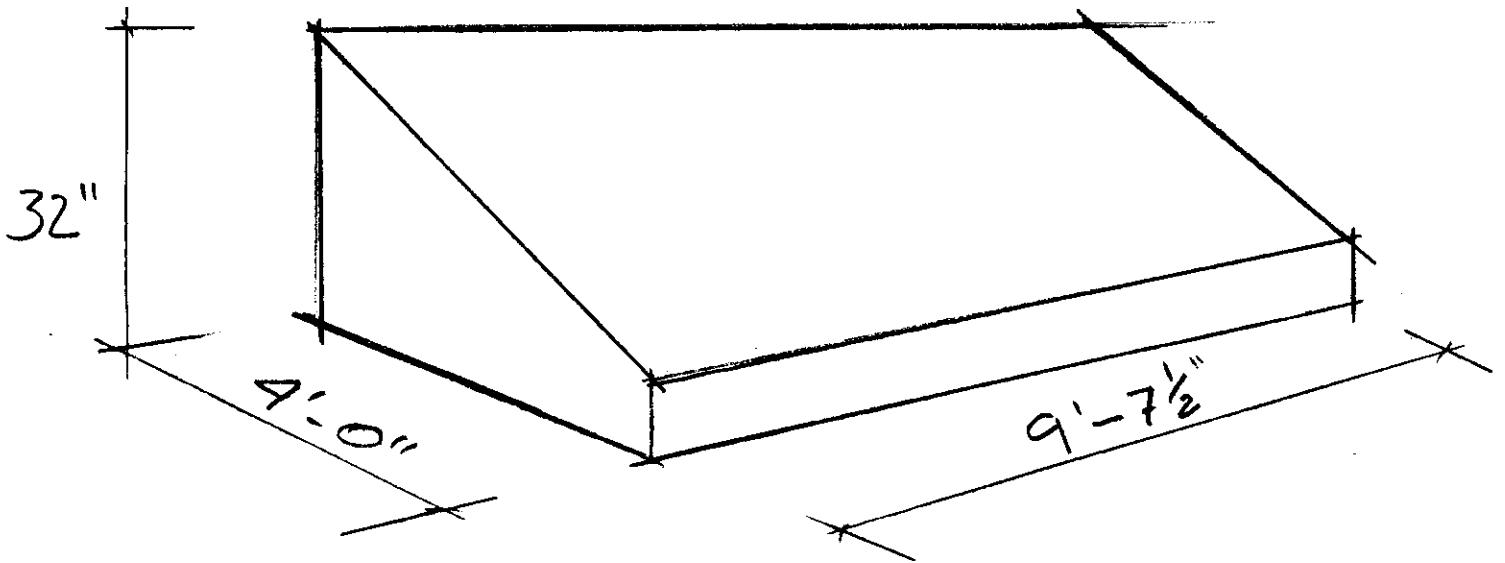

ARTS PRESCOTT GALLERY

134 S. MONTEZUMA

A SHADE BEYOND
474 EZ Street
Prescott, AZ 86301
928-778-9300

Awning fabric - Sunbrella Slate #4684

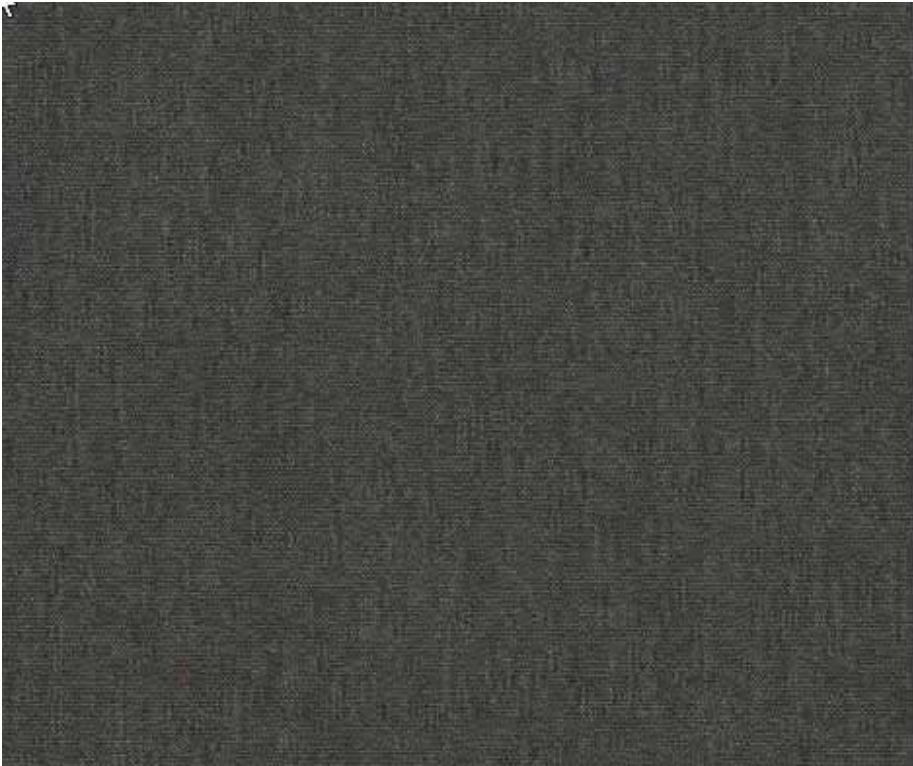

4684 SLATE

